

TWT- Portable Industrial Tools

- TWT Electric type hydraulic pipe bending machine works effortlessly bending pipe than the manual mechanical machines.
- Applied to general pipes, steel pipes, gas pipes, etc
- Pipe bending ranges up to 2" i.e 50.8mm and is designed to be portable.
- As compared to manual hydraulic bending, electrical hydraulic equipment makes more precisely bending up to 90 degree of cold bending pipes.
- TWT manual type hydraulic allows fast setup and disassembly.

Technical Specifications

- Model :- TWT - EH2
- Max Pressure : 13T
- Max Stroke: 250 mm
- Bending Dies: 1/2", 3/4", 1", 1 1/4", 1 1/2", 2", 2 1/2"
- Pipe Wall Thickness: 2.75-4.5mm
- Motor 750W

Electric Hydraulic Pipe Bending Machine

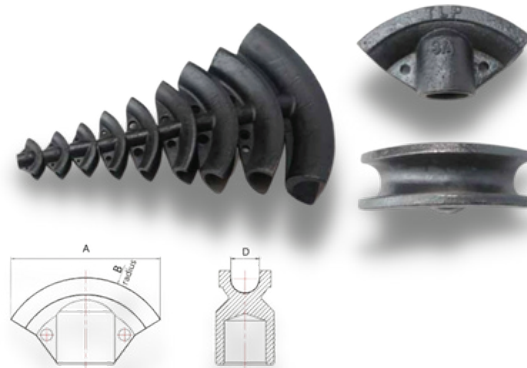

Bending Dies

TWT Product Specifications

TWT- Portable Industrial Tools

- TWT manual type hydraulic pipe bending machine works effortlessly bending pipe than the manual mechanical machines.
- Pipe bending ranges up to 2" i.e 50.8 mm and is designed to be portable.
- As compared to manual mechanical bending, hydraulic equipment makes more precisely bending up to 90 degree of cold bending pipes.
- TWT manual type hydraulic allows fast setup and disassembly.
- Option Tripod with or without Stand are available.

Manual Hydraulic Pipe Bending Machine



Technical Specifications

- Model :- TWT - MH2
- Max Pressure : 13T
- Max Stroke: 250 mm
- Bending Dies: 1/2", 3/4", 1", 1 1/4", 1 1/2", 2", 2 1/2"
- Pipe Wall Thickness: 2.75-4.5 mm

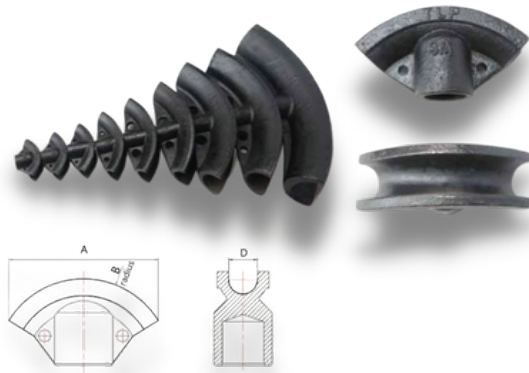

Bending Dies

TWT Product Specifications