

# TWE SERIES ELECTRIC TORQUE WRENCH

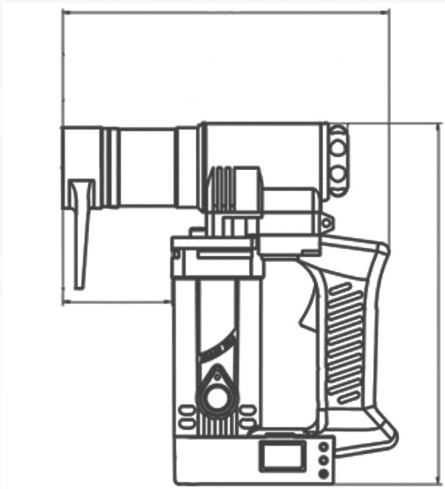

D

| Model  | Torque (Nm) | Direct Hex Available | Speed (RPM) | Weight (kg) | Overall Length A (mm) | Overall Width C | Diameter D |
|--------|-------------|----------------------|-------------|-------------|-----------------------|-----------------|------------|
| TWE-2  | 100-300     | M10, M12, M16        | 28          | 4           | 240                   | 267             | 80         |
| TWE-5  | 200-500     | M12, M16, M20        | 20          | 4.2         | 271                   | 267             | 111        |
| TWE-7  | 300-700     | M16, M20, M22        | 18          | 4.6         | 221                   | 269             | 54         |
| TWE-9  | 400-900     | M20, M22, M24        | 16          | 5.1         | 238                   | 275             | 71         |
| TWE-12 | 500-1200    | M22, M24, M27        | 14          | 6.3         | 225                   | 287             | 50         |
| TWE-17 | 800-1700    | M24, M27, M30        | 12          | 7           | 286                   | 287             | 81         |
| TWE-21 | 1000-2100   | M27, M30, M33        | 10          | 7.2         | 274                   | 286             | 95         |
| TWE-25 | 1100-2500   | M30, M33, M36        | 5           | 9           | 283                   | 293             | 107        |
| TWE-35 | 1700-3500   | M33, M36, M42        | 4.5         | 15          | 283                   | 293             | 107        |
| TWE-50 | 2000-5000   | M42, M45, M48        | 2.5         | 17          | 375                   | 301             | 273        |

| Model    | Torque Range (Nm) | Speed (RPM) | Weight (Kg) | Square Drive |
|----------|-------------------|-------------|-------------|--------------|
| TWES-3   | 100-300           | 28          | 4           | 3/4"         |
| TWES-5   | 200-500           | 20          | 4.2         | 3/4"         |
| TWES-7   | 300-700           | 18          | 4.6         | 1"           |
| TWES-9   | 400-900           | 16          | 5.1         | 1"           |
| TWES-12  | 500-1200          | 14          | 6.3         | 1"           |
| TWES-17  | 800-1700          | 4.5         | 7.0         | 1.1/2"       |
| TWES-21  | 1000-2100         | 5.5         | 7.2         | 1.1/2"       |
| TWES-25  | 1000-2500         | 5           | 9           | 1.1/2"       |
| TWES-35  | 1700-3500         | 4.5         | 15          | 1.1/2"       |
| TWES-40  | 2000-4000         | 3           | 17          | 1.1/2"       |
| TWES-60  | 3000-6000         | 2.5         | 18          | 1.1/2"       |
| TWES-100 | 5000-10000        | 2.5         | 21          | 2.1/2"       |

